

Hinged Steelbelt Conveyors

for the metalworking industry

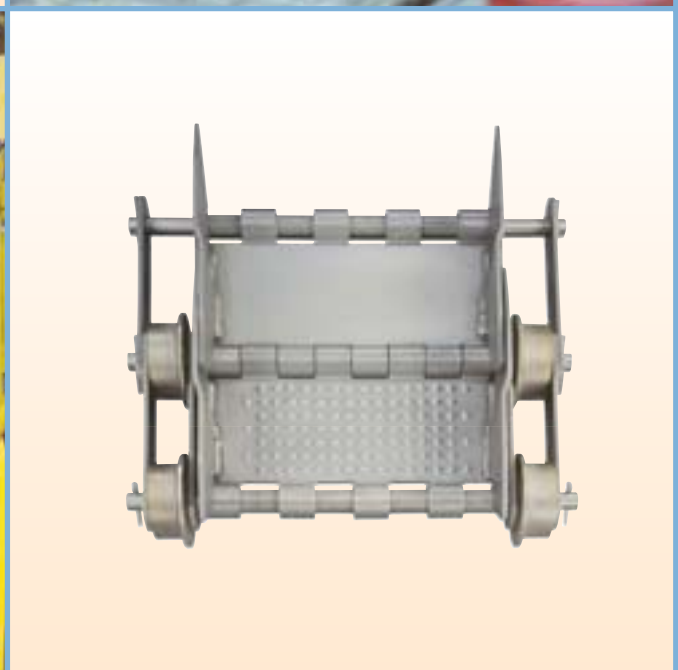

MAYFRAN - Conveyor systems

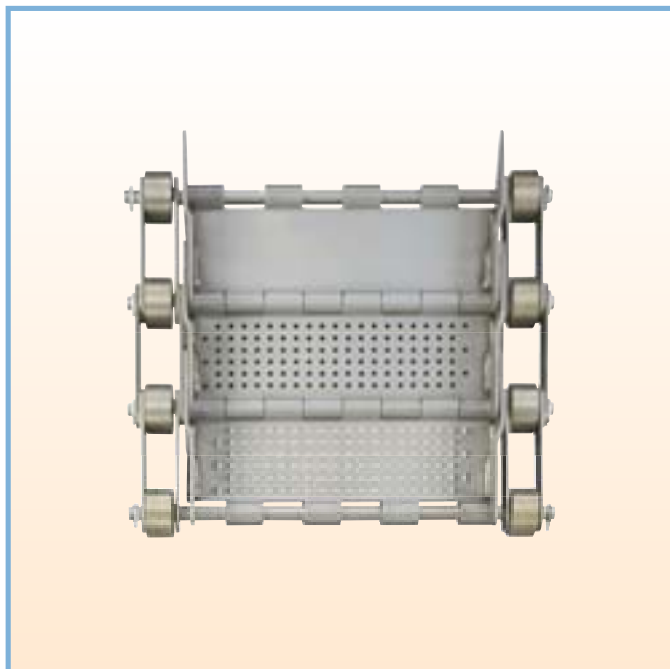
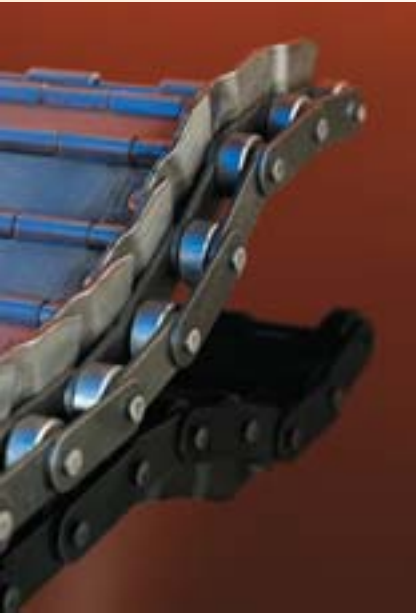

Your partner in the ...

- Automobile industry
- Automotive supply industry
- Household appliance industry
- Audio-Video-industry
- Electric industry
- Bodywork profile industry
- Casting-Industry

All major car manufacturers world wide, have been supplied with Mayfran conveyor systems. In Europe for more than 40 years our know-how has assured our customers a strong and reliable conveyor system. World wide more than 2000 systems have already been installed. Our steelbelt conveyors incorporate years of experience into the design ensuring a long and reliable life.

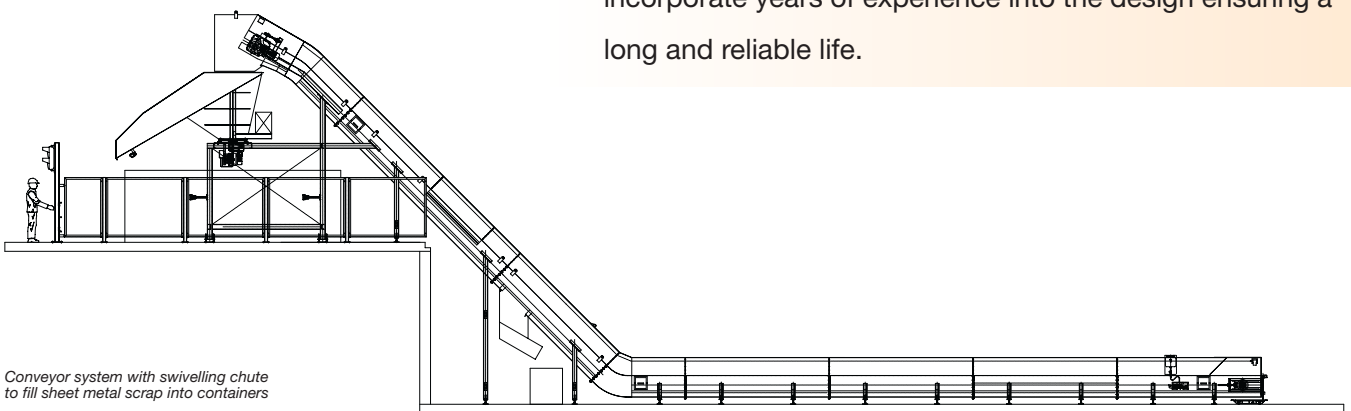

Conveyor system with swivelling chute to fill sheet metal scrap into containers

... reliable partner in the metalworking industry.



Belt types

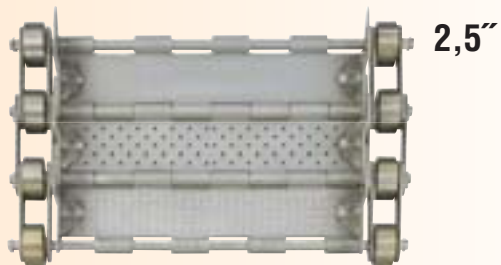

The hinged steelbelt is available in various designs, depending on the application.

Special features for severe applications are available.

4"

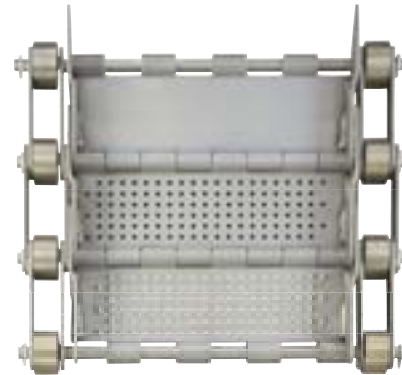

Belt plates with perforated or dimpled surfaces, welded loops, reinforced belt plates and reinforced cleats can be supplied for special applications.

9"

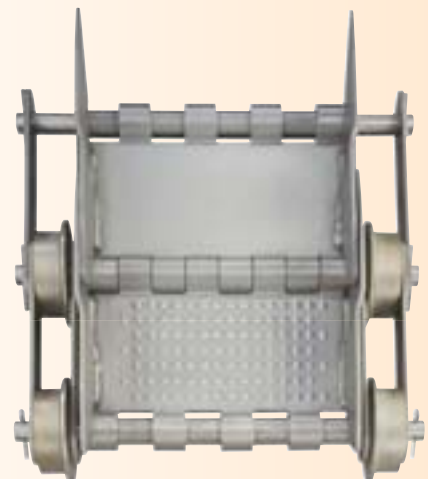

Solid construction and long life lasting ...

DIMENSIONS

Various sizes and dimensions are not a problem - the frame parts are assembled according to each individual case and the given conditions. The curve sections with wear resistant liners on the chain tracks can be varied in stages up to 45°, depending on the type of conveyed material. An oiltight frame can be supplied for applications involving lubricants.



Model A
Model B



Model C
Model D



... assure the availability.



Model	2,5" = 63,5 mm Plate thickness* 3 mm	4" = 101,6 mm Plate thickness* 4 mm	6" = 152,4 mm Plate thickness* 5 mm	9" = 228,6 mm Plate thickness* 6 mm
A/B	H to 25 m V to 3 m	H to 50 m V to 3 m	H to 90 m V to 3 m	H to 200 m V to 3 m
C	H to 20 m V to 4 m	H to 40 m V to 6 m	H to 80 m V to 6 m	H to 150 m V to 6 m
D	H to 20 m V to 3 m	H to 40 m V to 4 m	H to 70 m V to 5 m	H to 130 m V to 5 m
Frame height	220 mm	354 mm	550 mm	820 mm
max. Beltwidth	762 mm	1219 mm	1981 mm	2134 mm
conveying speed to	4 m/min	7 m/min	10 m/min	14 m/min

Approx. values vary depending on the application.

* Plate thickness for stamped belt plates. The thickness can be adjusted correspondingly for welded loops.

H = Sprocket distance horizontal
V = Sprocket distance vertical

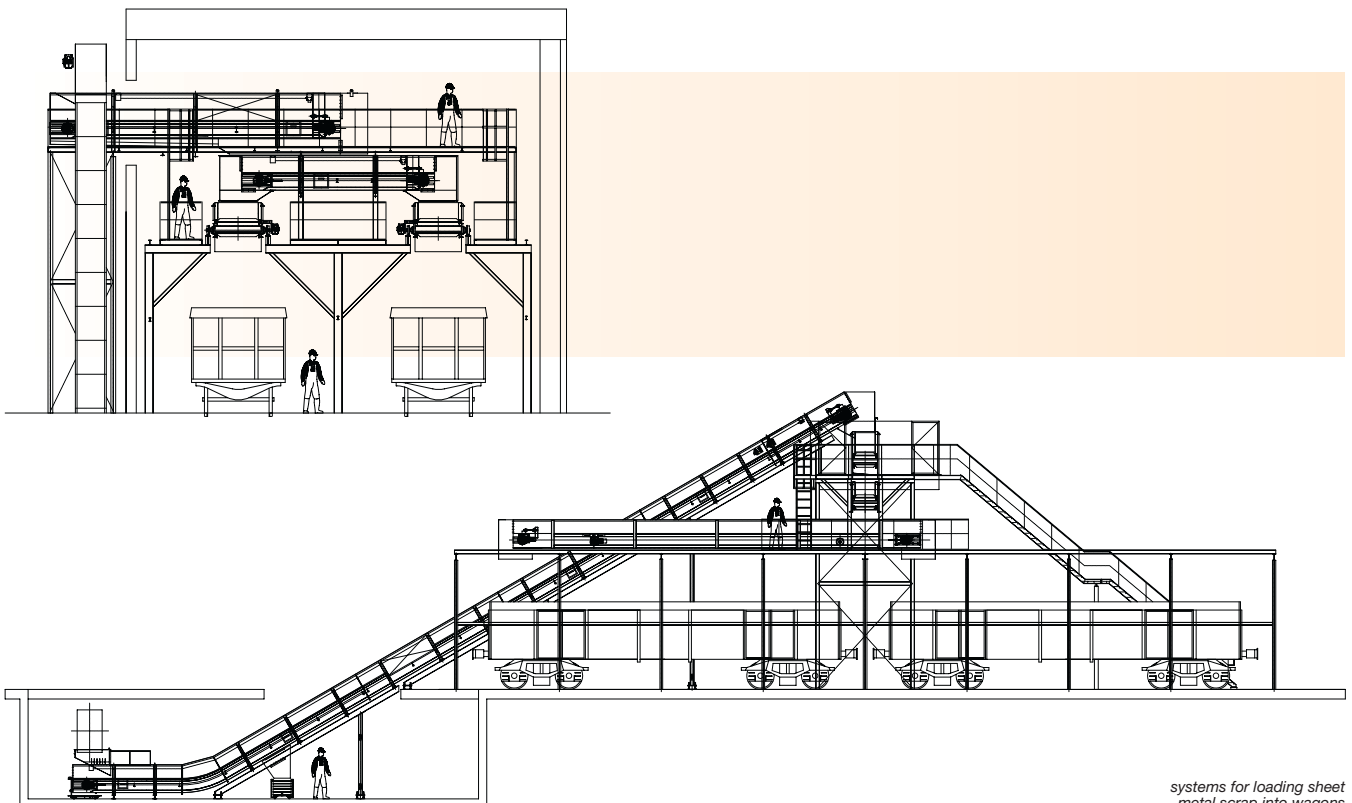

systems for loading sheet metal scrap into wagons

Different shapes allow ...

Chain design

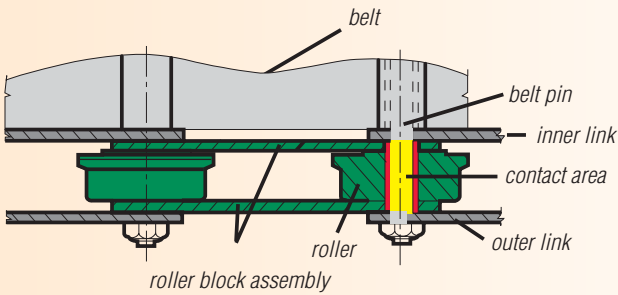

Mayfran chains are designed to avoid relative motion, thus minimising wear and prolonging the chain life.

Depending on the type of belt, a belt tube passes through the formed or welded hinged loops to link the individual belt plates. This simultaneously increases the resistance to sagging and envelops the full width belt pins.

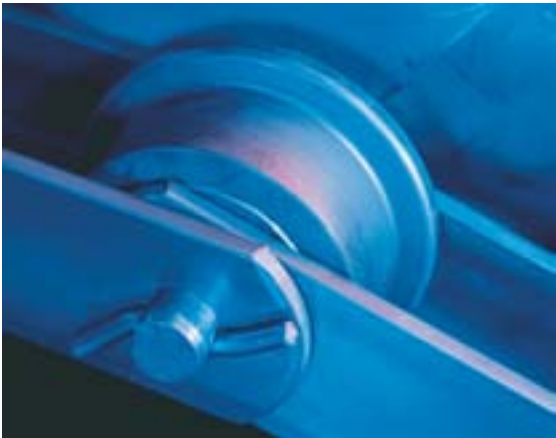
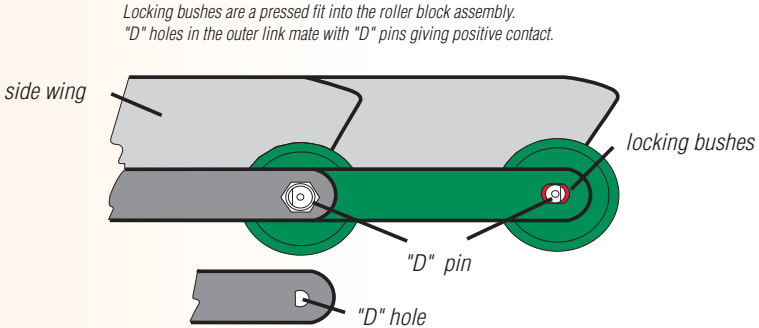

The belt pull is borne solely by the chains, thus reducing the tension on the belt plates. Standard belt widths are available from 305 mm to 2134 mm in 6" steps depending on the type of belt.

... the optimum solution.

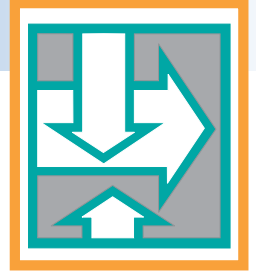

The conveyor frame

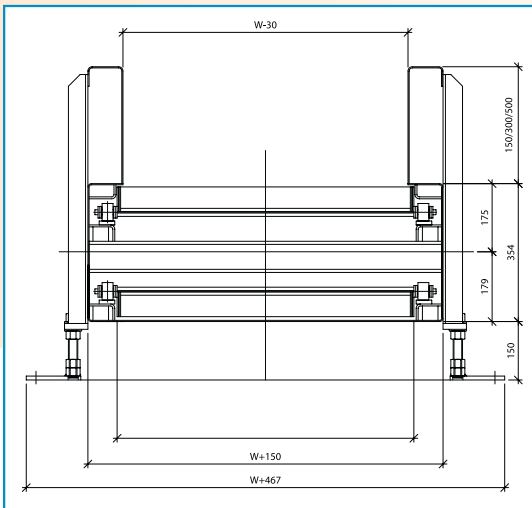

4" cross-section

Overlapping side wings prevent the ingress of parts or scrap into the chain running track, the skirts on the conveyor frame enable high volumes of material to

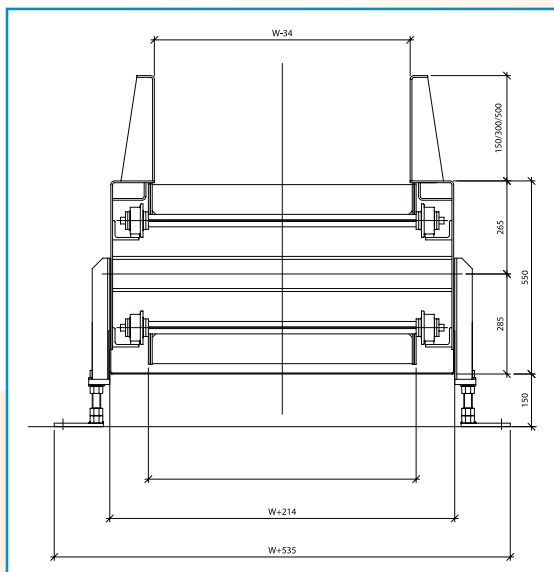

be handled and adjustable conveyor support legs ensure easy installation and compensate for uneven foundations.

6" cross-section



Serving Global Markets



www.mayfran.com

Mayfran International (Inc.)

P.O. Box 43038
Cleveland, OH 44143 U.S.A.
Tel.: +1 44 04 61 41 00
Fax: +1 44 04 61 55 65
info@mayfran.com

Mayfran International B.V.

P.B. 31032, Edisonstraat 7
6370 AA Landgraaf/Netherlands
Tel.: +31 4 55 32 92 92
Fax: +31 4 55 32 93 00
info@mayfran-europe.com

Tsubakimoto Mayfran Inc.

5001 Ohno, Tsuchiyama-Cho, Kouga-Gun
Shiga 528-02/Japan
Tel.: +81 7 48 67 10 01
Fax: +81 7 48 67 10 97

Korea Mayfran

72-1, Onsoo-dong
Kuro-ku 152-120, Seoul/Korea
Tel.: +82 26 11 58 86
Fax: +82 26 86 25 21

Miven Mayfran

P.O. Box 59 Karwar Road,
Hubli-580 024/India
Tel.: +91 8 36 30 36 77
Fax: +91 8 36 30 32 65

Mayfran GmbH

Roermonder Str. 594
D-52072 Aachen/Germany
Tel.: +49 2 41 93 87 20
Fax: +49 2 41 17 50 80
sales@mayfran-europe.com

Subsidiary South of GER

Richthofenstraße 32
D-73312 Geislingen/Steige
Tel.: +49 7 33 19 55 30
Fax: +49 7 33 19 55 355
sales@mayfran-europe.com

Mayfran U.K. Ltd.

Orchard Court IX, Binley Business Park
Harry Weston Road, Coventry CV3 2TQ/UK
Tel.: +44 24 76 45 90 00
Fax: +44 24 76 45 96 90

Mayfran France S.A.R.L.

Centre D'Affaires, Paris-Nord
Immeuble le Bonaparte,
F-93153 Le Blanc Mesnil Cedex/France
Tel.: +33 1 48 65 78 00
Fax: +33 1 48 65 66 55

Mayfran Canada Ltd.

5955 Airport Road, Suite 300
Mississauga, Ontario, Canada L4V 1R9
Tel.: +1 90 56 78 00 18
Fax: +1 90 56 78 00 19